



KARI Float Switch Operation

Manual



High level alarm



Issued when the level of liquid gets too high, or initiates valve discharging when, for example, the pump is out of order.

Start



Large amount of liquid. Discharging pump starts.

Stop



Lower limit for discharging. Discharging pump stops.



Image C3H shows the operation of the KARI Float Switch

KARI Float Switch

– compact and reliable

The KARI Float Switch is a control device for charging and discharging pumps and motor and magnetic valves. It is also an alarm device that alerts the user at specified surface levels. SGS FIMKO Oy (the Finnish Electrical Inspectorate) has performed testing in accordance with the Low Voltage Directive (LVD) and approved the KARI Float Switch for use in non-flammable liquids at 250 volts.

FUNCTIONS

DISCHARGING-PUMP CONTROL

C3H	Discharging-pump control + high level alarm.
C3HE	Discharging-pump control + isolated high level alarm.

CHARGING-PUMP CONTROL

C3L	Charging-pump control + low level alarm.
C3LE	Charging-pump control + isolated low level alarm.

ORDER CODE

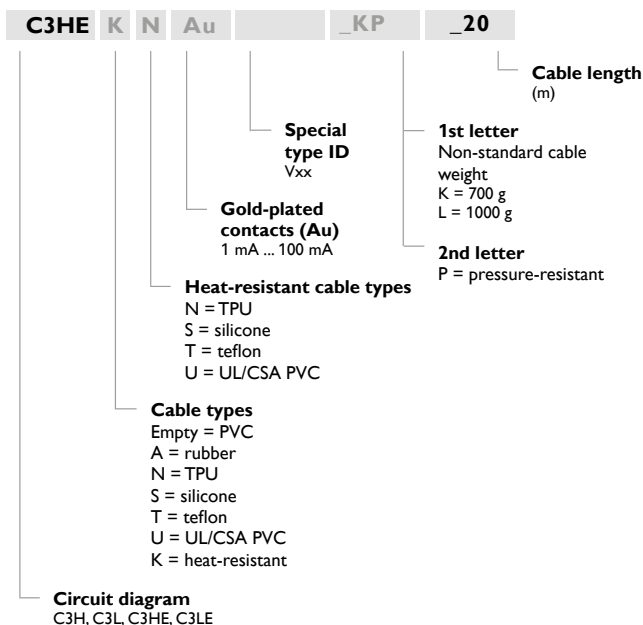

CIRCUIT DIAGRAM

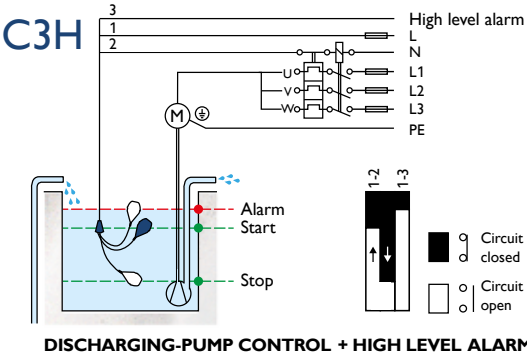

DISCHARGING-PUMP CONTROL + HIGH LEVEL ALARM

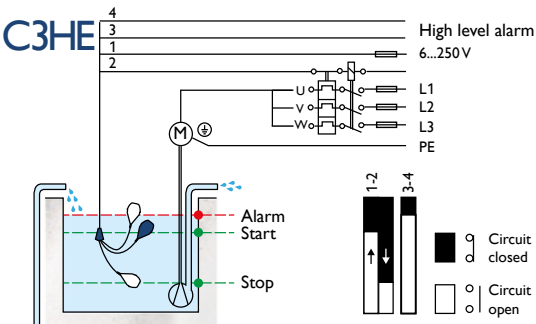

DISCHARGING-PUMP CONTROL + ISOLATED HIGH LEVEL ALARM

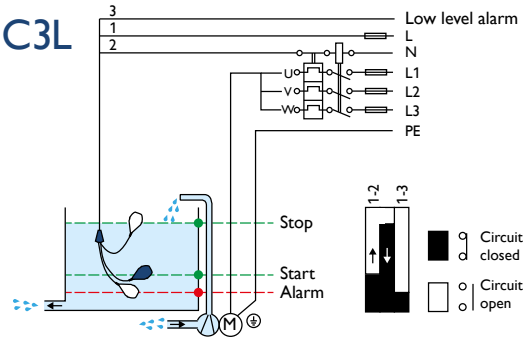

CHARGING-PUMP CONTROL + LOW LEVEL ALARM

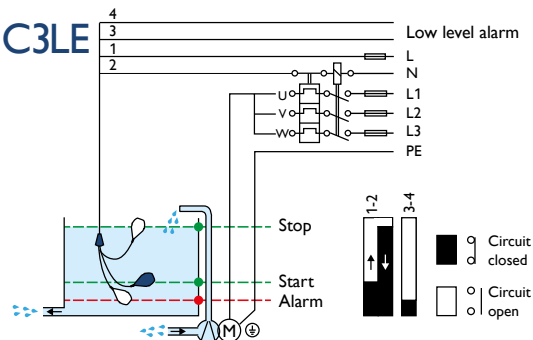

CHARGING-PUMP CONTROL + ISOLATED LOW LEVEL ALARM

INSTALLATION AND ADJUSTMENT

The KARI Float Switch is mounted to hang from its own cable. The float switch floats on the surface of the liquid and follows the movement of the liquid's surface. Functions are controlled in the various tilt angles of the float. The switching distance differential is adjusted by moving the weight along the cable.

Installation considerations

- The height at which the float hangs and the distance of the cable weight from the float can be adjusted. The differential between the start and stop levels is at its lowest when the cable weight is about 10 cm from the tip of the float's strain-relief (see page 6).
- If the viscosity of the liquid is high or floating to the sides needs to be restricted, we recommend a heavier weight of cable, which we supply as required. The weights are fixed to the cable with a clamp wedge (see Image 1 on the next page).
- It is important to keep the junction box in a dry environment. If this is not possible, the ends of float switch cables must be covered with, for example, protective grease (see Images 2 and 3 on the next page). An IP68 junction box is also available.
- The float switch needs a cable weight or other anchor point to operate.
- The installation site must be selected such that the float cannot become caught under or stay on top of any surface or get entangled in other structures (see Image 4 on the next page).
- When the float switch is tested without being floated, its correct orientation must be considered: the 'UP' mark on the side of the bottom portion must face upward. For example, when placed on the floor on its side, the float switch settles into this position because of its internal keel weight (see Image 5 on the next page).
- Tying the float switch from its cable near the float to, for example, the ascension pipe of the pump decreases the useful life of the cable; the float switch should hang freely from its cable (as shown in Image on the next page 6).

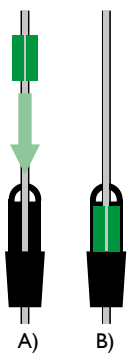

Image 1. Cable weights and the hanging loop are fixed to the cable with a clamp wedge (A–B).

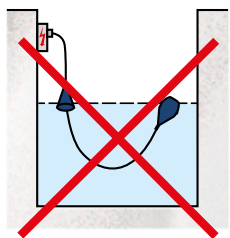

Image 2. Avoid extending or connecting the cable in humid conditions.

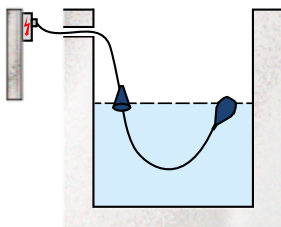

Image 3.

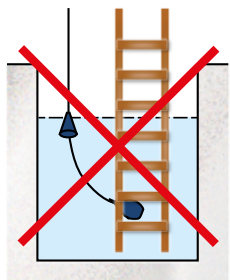

Image 4. Take care to ensure the free movement of the float.

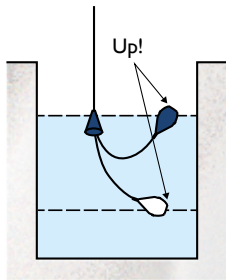

Image 5. Note the correct orientation of the float.

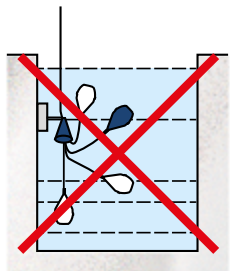
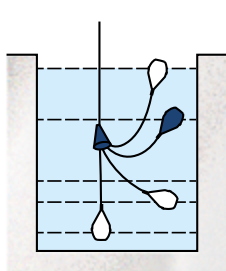

Image 6. Avoid fixing the float such that a sharp corner can cause kinks or wear to the cable.



TECHNICAL INFORMATION

Switching element	Microswitch
Voltage	6 ... 250V AC
Max. rated current	6A res., 3A ind.
Rated current with gold-plated contacts	1 mA ... 100 mA
Maximum DC power	75 VA (=0,3A, 250V)
Pressure rating for special types	200 kPa
Max. operating temperature	+55 °C (+75 °C supplied to order)
Range of adjustment for standard product (start to stop)	200 mm ... 1200 mm
Cable length	5 m (other lengths supplied to order)
Weight of 5 m cable	1,25 kg... 1,35 kg
Largest diameter	99 mm
Length of float casing	140 mm
Buoyancy in water	4 N
Float material	Polypropylene (PP)
Cable insulation (standard)	PVC
Other cable options	Rubber, TPU, teflon, silicone
Water-tightness	IP 67

OPERATING CURVE

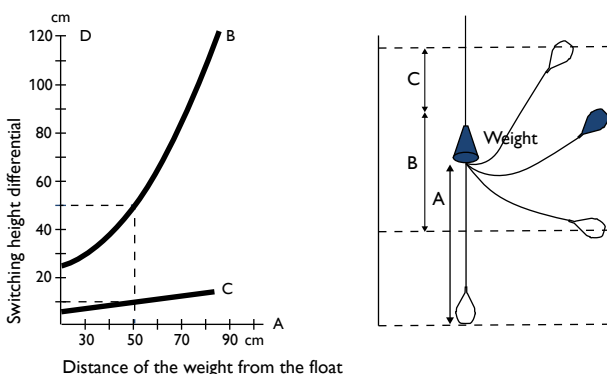

The dimensions in the drawings are for illustrative purposes only.

The switching height differential is adjusted to the required level by means of the cable weight. Curve B shows the start- and stop-height differential of the KARI Float Switch in relation to the distance of the weight from the float. Curve C shows the corresponding differential between start and alarm levels. Example: For a type 3H float switch, if the distance of the weight from the bottom of the float (A) is 50 cm, the start/alarm height differential is about 12 cm.

DIMENSIONS

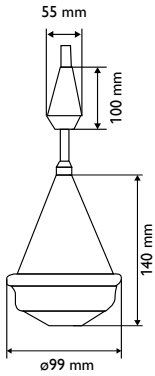

A QUALITY FINNISH PRODUCT

Our quality control is based on the ISO 9001 quality management system. Each product is subject to a full operation test. The KARI Float Switch is also available in versions which fulfill the U.S. and Canadian national safety standards.



ROHS



Kari-Finn Oy
Koneharjuntatu 1
FI-15850 LAHTI
Tel. +358 3 876 810
info@kari.fi
www.kari.fi



Over 50 years of experience in product development

Kari-Finn Oy developed its first float switch back in 1965. Since then, we have designed, tested, and manufactured millions of float switches, for a wide variety of operating environments. Thanks to our research work and feedback from customers, we have been very successful in developing our product line.

International success in innovation and export since 1977

It was several decades ago, in 1977, when the KARI Float Switch was awarded a gold medal at the Brussels International Exhibition of Invention and a medal of the City of Brussels for an extensively exported product. At that time, exports covered all countries in Europe, the United States, South Africa, and Japan. Later on, exports reached every continent.



Sektorii 09/2015

● Agents

● Head office