

Bourdon tube pressure gauge with switch contacts Model 232.30.063, stainless steel safety version

WIKA data sheet PV 22.03



switchGAUGE

Applications

- Control and regulation of industrial processes
- Monitoring of plants and switching of electric circuits
- For gaseous and liquid aggressive media that are not highly viscous or crystallising, also in aggressive ambience
- Process industry: For the monitoring of gas cylinders and reducing regulators

Special features

- High reliability and long service life
- Up to 2 switch contacts per instrument
- Gauges with inductive contacts for use in hazardous areas with ATEX approval
- Gauges with electronic contacts for PLC applications
- Gauges in safety version S3 (S)



switchGAUGE model 232.30.063

Description

Wherever the process pressure has to be indicated locally, and, at the same time, circuits are to be made or broken, the Model 232.30.063 switchGAUGE can be used.

Switch contacts (electrical alarm contacts) make or break an electric control circuit dependent upon the position of the instrument pointer. The switch contacts are adjustable over 80 % of the scale range and are mounted predominantly below the dial.

The instrument pointer (actual value pointer) moves freely across the entire scale range, independent of the setting. The set pointer can be adjusted using a removable adjustment key in the window.

Switch contacts consisting of several contacts can also be set to a single set point. Contact actuation is made when the actual value pointer travels beyond or below the desired set point.

As switch contacts magnetic snap-action contacts, Reed switch, inductive contacts - for requirements to ATEX - or electronic contacts for triggering a PLC are available. For further information on the different switch contacts please see data sheet AC 08.01.

Standard version

Nominal size in mm

63

Accuracy class

1.6

Scale ranges

0 ... 4 to 0 ... 400 bar

or all other equivalent vacuum or combined pressure and vacuum ranges

Pressure limitation

Steady: 3/4 x full scale value

Fluctuating: 2/3 x full scale value

Short time: full scale value

Not suitable for dynamic load cycles

Operating temperature

Ambient: -20 ... +60 °C

Medium: +100 °C maximum

Temperature effect

When the temperature of the measuring system deviates from the reference temperature (+20 °C):

max. ± 0.4 %/10 K of full scale value

Process connection

Stainless steel 1.4571,

lower mount (LM) or lower back mount (LBM)

G 1/4 B (male), 14 mm flats

Pressure element

Stainless steel 316L, C-type

Movement

Stainless steel

Dial

Aluminium, white, black lettering

Pointer

Instrument pointer: aluminium, black

Set pointer: red

Case

Stainless steel, with solid baffle wall and blow-out back

Window

Polycarbonate

Bezel ring

Cam ring (bayonet type), stainless steel

Electrical connection

Cable gland with 2 m cable

Ingress protection

IP 54 per EN 60529 / IEC 529

Switch contacts

Magnetic snap-action contact model 821

- No control unit and no extra power supply required
- Direct switching up to 230 V
- Up to 2 switch contacts per measuring instrument

Inductive contact model 831

- Long service life due to non-contact sensor
- Additional control unit required
- With corresponding control unit suitable for use in Zone 1 (2 G) hazardous areas
- Low reaction on the display accuracy
- Fail-safe switching at high switching rates
- Insensitive to corrosion
- Up to 2 switch contacts per measuring instrument

Electronic contact model 830 E

- For direct triggering of a programmable logic controller (PLC)
- No additional control unit required
- Long service life due to non-contact sensor
- Low reaction on the display accuracy
- Fail-safe switching at high switching rates
- Insensitive to corrosion
- Up to 2 switch contacts per measuring instrument

Reed switch model 851

- No control unit and no extra power supply required
- Direct switching up to 150 V, 0,5 A
- Also suitable for direct triggering of a programmable logic controller (PLC)
- Free from wear as without contact

Switching function

The switching function of the switch is indicated by function index 1, 2 or 3.

Model 8XX.1: Contact makes (clockwise rotary motion of the pointer)

Model 8XX.2: Contact breaks (clockwise rotary motion of the pointer)

Model 821.3: Change-over; one contact breaks and one contact makes simultaneously when pointer reaches set point

For further information please see data sheet AC 08.01, electrical switch contacts

Options

- Other process connection
- Inductive contacts also in safety version
- Dual scale
- Panel mounting flange, polished stainless steel
- Surface mounting lugs on case, stainless steel
- Electrical connection: Miniature connector
- Ingress protection IP 65

Dimensions in mm

switchGAUGE model 232.30.063

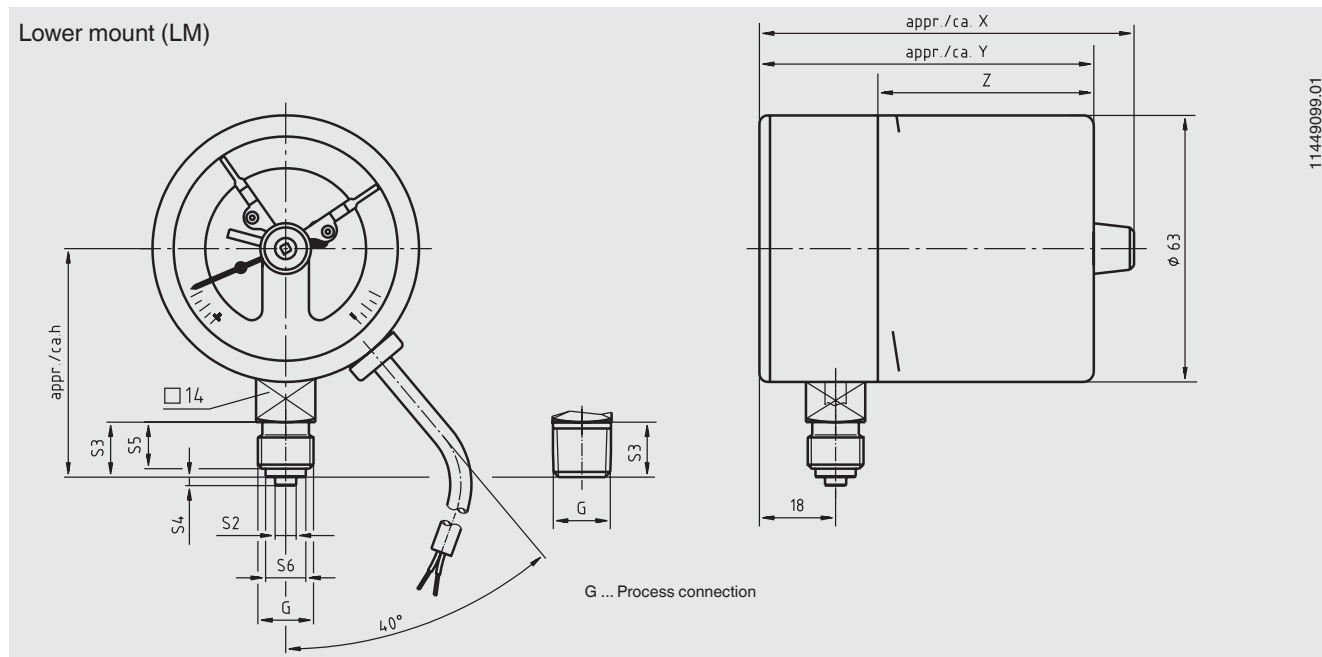

11449099.01

Type of contact Model	Dimensions in mm		
	X	Y	Z
821, Single contact	73.5	64	36
821, Double contact (SPDT)	83.5	74	46
83X, Single contact	83.5	74	46

Process connection	Dimensions in mm					
	h ± 1	S2	S3	S4	S5	S6
G ¼ B	54	5	13	2	11	9.5
G ⅛ B	51	-	10	-	8	8
¼ NPT	54	-	13	-	-	-
⅛ NPT	51	-	10	-	-	-

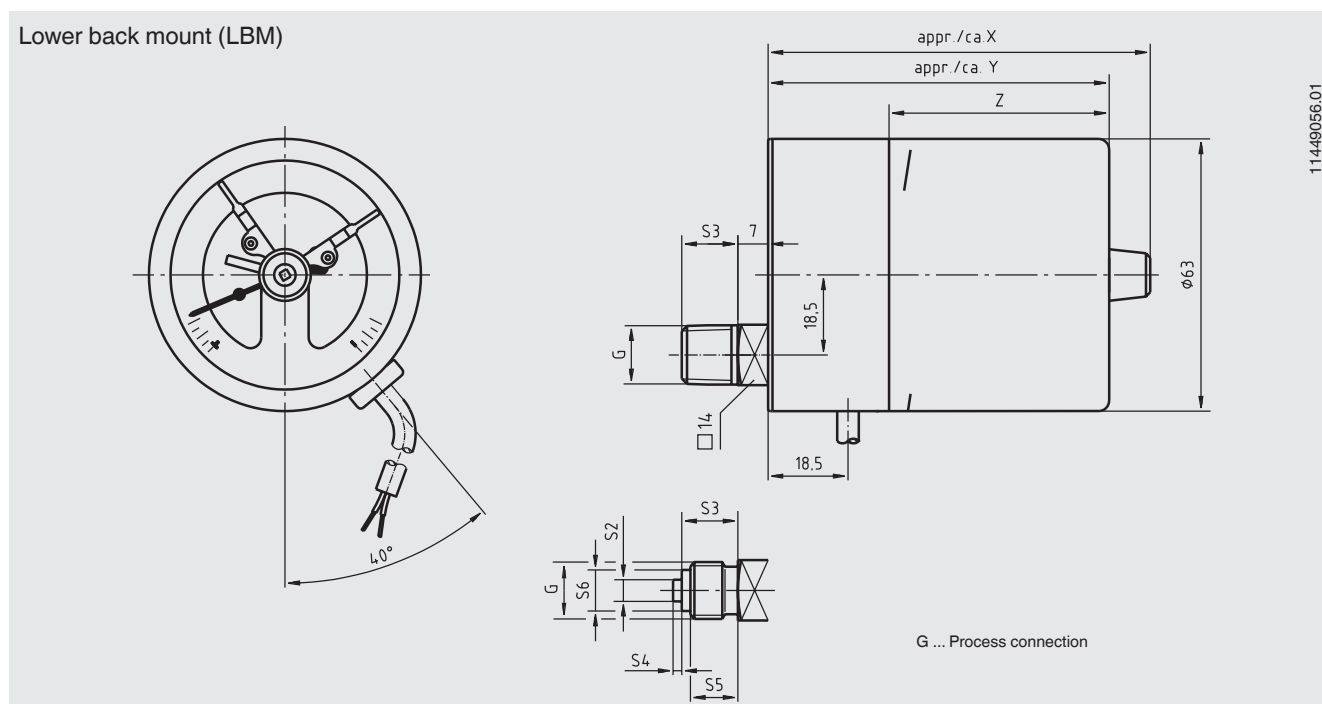

11449056.01

Type of contact Model	Dimensions in mm		
	X	Y	Z
821, Single contact	73.5	64	36
821, Double contact (SPDT)	83.5	74	46
83X, Single contact	83.5	74	46

Process connection	Dimensions in mm				
	S2	S3	S4	S5	S6
G ¼ B	5	13	2	11	9.5
G ⅛ B	-	10	-	8	8
¼ NPT	-	13	-	-	-
⅛ NPT	-	10	-	-	-

Ordering information

Model / Nominal size / Type of contact and switching function / Scale range / Connection size / Connection location / Options

The specifications given in this document represent the state of engineering at the time of publishing.
We reserve the right to make modifications to the specifications and materials.



WIKAI Alexander Wiegand SE & Co. KG
Alexander-Wiegand-Straße 30
63911 Klingenberg/Germany
Tel. (+49) 9372/132-0
Fax (+49) 9372/132-406
E-mail info@wika.de
www.wika.de