

Diaphragm seal with flange connection With flush diaphragm Model 990.27

WIKA data sheet DS 99.27



for further approvals
see page 3

Applications

- Chemical process industry
- Petrochemical industry
- For aggressive, highly viscous, crystallising or hot media

Special features

- Flange with a flush welded diaphragm
- Available for all common standards and nominal diameters
- When special materials are selected, all wetted parts (diaphragm and sealing face) are made of the selected material

Description

Diaphragm seals are used to protect the pressure measuring instrument from aggressive, adhesive, crystallising, corrosive, highly viscous, environmentally hazardous or toxic media. A diaphragm made of the appropriate material provides for the separation from the medium to be measured. Thus even the most difficult measuring requirements can be met by combining measuring instruments with diaphragm seals.

A fluid inside the system, which can be chosen to suit the particular application, hydraulically transmits the pressure to the measuring instrument.

Almost limitless application possibilities exist due to the large number of available variants, such as diaphragm seal designs or materials. The type of process connection (flange, threaded and sterile connection) and the basic method of manufacture are important design differentiation criteria.

For further technical information on diaphragm seals and diaphragm seal systems see IN 00.06 "Application, operating principle, designs".



Diaphragm seal with flange connection, model 990.27

Due to its design, the model 990.27 diaphragm seal with flange connection and flush diaphragm is suitable for all currently used standard flanges and is mounted for pressure measurement in lieu of a blind flange.

Assembly of the diaphragm seal and measuring instrument is made via a direct assembly as standard or optionally via a cooling element or a flexible capillary.

For the material selection WIKA offers a variety of solutions, in which the upper part and the diaphragm can be made of identical or different materials. The diaphragm and the sealing face can also be offered coated or covered with foils.

Measuring systems with model 990.27 WIKA diaphragm seals are successfully used worldwide in the chemical process and petrochemical industries with high measuring requirements.

Standard version

Process connection

Flanges

Standard	Nominal width	Sealing face
following EN 1092-1	DN 25	Form B1
	DN 40	
	DN 50	
	DN 65	
	DN 80	
	DN 100	
	DN 125	
following ASME B 16.5	1"	RF 125 ... 250 AA
	1 1/2"	
	2"	
	2 1/2"	
	3"	
	4"	
	5"	

Nominal pressure

See tables page 5 and 6

Measuring ranges

max. 0 ... 400 bar

Material of upper body

Stainless steel 1.4404 (316 L)

Material of wetted parts

Sealing face: Stainless steel 1.4404 (316L)

Diaphragm: Stainless steel 1.4435 (316L)

Level of cleanliness of wetted parts

Oil and grease free per ASTM G93-03 level E (WIKA standard) and ISO 15001 (< 550 mg/m²)

Connection to the measuring instrument

Axial weld-in connection

Installation example

Diaphragm seal, flange connection, model 990.27 with pressure gauge

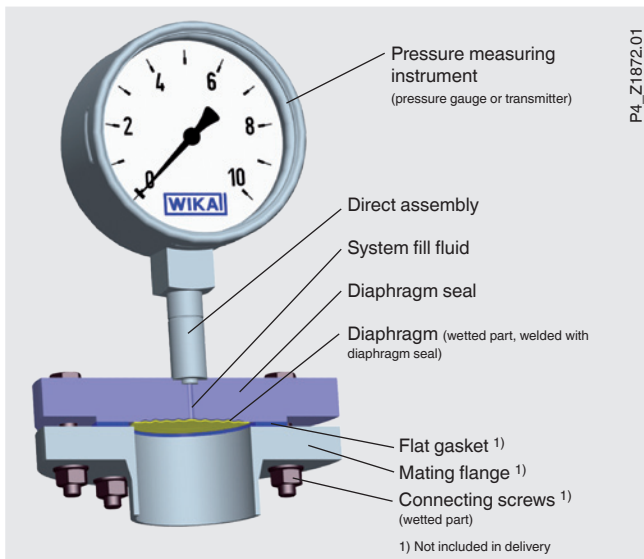

Options

Process connection

Standard	Nominal width	Sealing face
following EN 1092-1	DN 25	Form B2
	DN 40	Form C (tongue) ¹⁾
	DN 50	Form D (groove) ¹⁾
	DN 65	Form E (spigot with form B1) ¹⁾
	DN 80	Form E (spigot with form B2) ¹⁾
	DN 100	Form F (recess with form B1) ¹⁾
	DN 125	Form F (recess with form B2) ¹⁾
following ASME B 16.5	1"	RF SF
	1 1/2"	Small tongue
	2"	Large tongue
	2 1/2"	Large male face
	3"	Small male face
	4"	Small groove
	5"	Large groove
following API	1 1/8"	RJF groove
	1 1/16"	
	1 13/16"	
	2 1/16"	
following JIS	DN 25A	RF 125 ... 250 AA
	DN 40A	
	DN 50A	
	DN 80A	
	DN 100A	

¹⁾ max. PN 100

(limited with special materials, on request)

Other flanges on request

- Flushing ring
 - Stainless steel 316L, for connection DN 40 ... 125 per EN or DN 1 1/2" ... 5" per ASME (see data sheet AC 91.05)
- Connection to the measuring instrument
 - G 1/2, G 1/4, 1/2 NPT or 1/4 NPT (female)
- Higher level of cleanliness of wetted parts
 - Oil and grease free per ASTM G93-03 level D and ISO 15001 (< 220 mg/m²)
 - Oil and grease free per ASTM G93-03 level C and ISO 15001 (< 66 mg/m²)
- Design per NACE (MR 0175 or MR 0103)
- Origin of wetted parts (EU, CH, USA)

Additional information for diaphragm seal systems

See Technical information IN 00.06 "Diaphragm seals - Diaphragm seal systems, application, operating principle, designs"

- Pressure measuring instrument model
- Connection to the measuring instrument: Direct assembly (calibrated in vertical mounting position, process connection facing downwards)
- Process temperature
- Ambient temperature
- System fill fluid

Options for diaphragm seal systems

- Connection to the measuring instrument via cooling element or capillary
- Height difference between measuring point and pressure measuring instrument with capillary in meter increments (max. 7 m with silicone oils)
- Vacuum service (suitable for vacuum operation)
- Diaphragm seals for mounting to zone 0
 - with flame arrester
 - with flame arrester and PTB certificate
- Mounting bracket (required for connection to the measuring instrument via capillary)
 - Form H per DIN 16281, 100 mm, aluminium, black
 - Form H per DIN 16281, 100 mm, stainless steel
 - Bracket for pipe mounting, for pipe \varnothing 20 ... 80 mm, steel

Approvals

- **GOST-R**, import certificate, Russia
- **CRN**, safety (e.g. electr. safety, overpressure, ...), Canada

Certificates ¹⁾

- 2.2 test report per EN 10204 (e.g. state-of-the-art manufacturing, material proof, indication accuracy for diaphragm seal systems)
- 3.1 inspection certificate per EN 10204 (e.g. material proof for wetted metallic parts, indication accuracy for diaphragm seal systems)

1) Option

Approvals and certificates, see website

Materials

Upper body	Wetted part	Diaphragm	Process temperature limit in °C
Sealing face			
Standard			
Stainless steel 1.4404 (316L)	Stainless steel 1.4404	Stainless steel 1.4435	400
Option			
Stainless steel 1.4404 (316L)	Stainless steel 1.4539 (904L)	Stainless steel 1.4539 (904L)	400
	Stainless steel 1.4541 (321)	Stainless steel 1.4541 (321)	400
	Stainless steel 1.4571 (316Ti)	Stainless steel 1.4571 (316Ti)	400
	ECTFE coating	ECTFE coating	150 ¹⁾
	PFA coating	PFA coating	260 ¹⁾
	Gold plating	Gold plating	400 ¹⁾
	PTFE foil	PTFE foil	260 ¹⁾
	Wikaramic®	Wikaramic®	400 ¹⁾
	Hastelloy C22 (2.4602)	Hastelloy C22 (2.4602)	260 ¹⁾
	Hastelloy C276 (2.4819)	Hastelloy C276 (2.4819)	400 ^{1) 2)}
	Inconel 600 (2.4816)	Inconel 600 (2.4816)	400 ¹⁾
	Inconel 625 (2.4856)	Inconel 625 (2.4856)	400 ¹⁾
	Incoloy 825 (2.4858)	Incoloy 825 (2.4858)	400 ¹⁾
	Monel 400 (2.4360)	Monel 400 (2.4360)	400 ¹⁾
	Nickel	Nickel	260 ¹⁾
	Titanium (3.7035)	Titanium (3.7035)	150 ¹⁾
	Titanium (3.7235)	Titanium (3.7235)	150 ¹⁾
	Tantalum	Tantalum	300 ^{1) 2)}
Stainless steel 1.4435 (316L)	Stainless steel 1.4435 (316L)	Stainless steel 1.4435 (316L)	400
Stainless steel 1.4539 (904L)	Stainless steel 1.4539 (904L)	Stainless steel 1.4539 (904L)	400
Stainless steel 1.4541 (321)	Stainless steel 1.4541 (321)	Stainless steel 1.4541 (321)	400
Stainless steel 1.4571 (316Ti)	Stainless steel 1.4571 (316Ti)	Stainless steel 1.4571 (316Ti)	400
Duplex 2205 (1.4462)	Duplex 2205 (1.4462)	Duplex 2205 (1.4462)	300
Superduplex (1.4410)	Superduplex (1.4410)	Superduplex (1.4410)	300
Hastelloy C22 (2.4602)	Hastelloy C22 (2.4602)	Hastelloy C22 (2.4602)	400
Hastelloy C276 (2.4819)	Hastelloy C276 (2.4819)	Hastelloy C276 (2.4819)	400
Inconel 600 (2.4816)	Inconel 600 (2.4816)	Inconel 600 (2.4816)	400
Inconel 625 (2.4856)	Inconel 625 (2.4856)	Inconel 625 (2.4856)	400
Incoloy 825 (2.4558)	Incoloy 825 (2.4858)	Incoloy 825 (2.4858)	400
Monel 400 (2.4360)	Monel 400 (2.4360)	Monel 400 (2.4360)	400
Nickel	Nickel	Nickel	400
Titanium (3.7035)	Titanium (3.7035)	Titanium (3.7035)	400
Titanium (3.7235)	Titanium (3.7235)	Titanium (3.7235)	400

1) Combination of materials for upper body and wetted parts only possible in connection with form B2 sealing faces and RFSF

2) Combination of materials for upper body and wetted parts only possible in connection with form B1 sealing faces and RF 125 ... 250 AA with DN 50, DN 80 and 2", 3"

Further material combinations and process temperature limits on request

Dimensions in mm

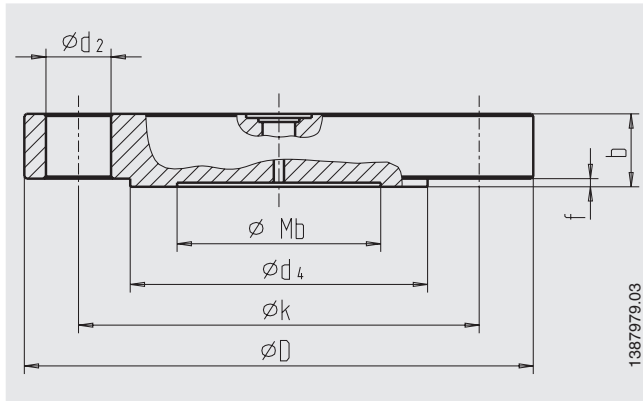

Flange connection following EN 1092-1, form B1

DN in mm	PN in bar	Dimensions in mm					Raised face			Weight in kg
		Mb	D	b	d ₂	k	f	d ₄	x	
25	10/40	32	115	18	14	85	2	68	4	1.5
	63/100	25	140	24	18	100	2	68	4	2.5
40	10/40	45	150	18	18	110	2	88	4	2.6
	63/100	45	170	26	22	125	2	88	4	4.0
	160	45	170	28	22	125	2	88	4	4.3
	250	45	185	34	26	135	2	88	4	6.3
50	10/40	59	165	20	18	125	2	102	4	3.3
	63	59	180	26	22	135	2	102	4	5.1
	100	59	195	28	26	145	2	102	4	6.5
	160	59	195	30	26	145	2	102	4	7.0
	250	59	200	38	26	150	2	102	8	9.3
80	10/16	89	200	20	18	160	2	138	8	4.9
	25/40	89	200	24	18	160	2	138	8	5.8
	63	89	215	28	22	170	2	138	8	7.9
	100	89	230	32	26	180	2	138	8	10.4
	160	89	230	36	26	180	2	138	8	11.7
	250	89	255	46	30	200	2	138	8	18.4
100	10/16	89	220	20	18	180	2	158	8	5.9
	25/40	89	235	24	22	190	2	162	8	8.1
	63	89	250	30	26	200	2	162	8	11.5
	100	89	265	36	30	210	2	162	8	15.5
	160	89	265	40	30	210	2	162	8	17.3
	250	89	300	54	33	235	2	162	8	29.9
125	10/16	124	250	22	18	210	2	188	8	8.4
	25/40	124	270	26	26	220	2	188	8	11.6
	63	124	295	34	30	240	2	188	8	16.5
	100	124	315	40	33	250	2	188	8	24.4
	160	124	315	44	33	250	2	188	8	26.9
	250	124	340	60	33	275	2	188	12	42.7

Mb = effective diameter of diaphragm, x = number of drill holes

Further dimensions and higher nominal pressures on request

Flange connection per ASME B 16.5, raised face

DN	Class	Dimensions in mm					Raised face			Weight in kg
		Mb	D	b	d ₂	k	f	d ₄	x	
1"	150	32	110	14.7	16	79.4	2	51	4	1.4
	300	32	125	17.9	19	88.9	2	51	4	1.7
1 1/2"	150	45	125	17.9	16	98.4	2	73	4	1.6
	300	45	155	21.1	22	114.3	2	73	4	2.5
	600	45	155	29.3	22	114.3	7	73	4	3.3
	1,500	45	180	38.8	29	123.8	7	73	4	5.9
	2,500	45	205	51.5	32	146	7	73	4	10.4
2"	150	59	150	19.5	19	120.7	2	92	4	2.7
	300	59	165	22.7	19	127	2	92	8	3.7
	600	59	165	32.4	19	127	7	92	8	5.7
	1,500	59	215	45.1	26	165.1	7	92	8	13.2
	2,500	59	235	57.9	29	171.4	7	92	8	19.8
3"	150	89	190	24.3	19	152.4	2	127	4	5.3
	300	89	210	29	22	168.3	2	127	8	7.8
	600	89	210	38.8	22	168.3	7	127	8	11
	900	89	240	45.1	26	190.5	7	127	8	16.7
	1,500	89	265	54.7	32	203.2	7	127	8	24.5
	2,500	89	305	73.7	35	228.6	7	127	8	42.7
4"	150	89	230	24.3	19	190.5	2	158	8	7.7
	300	89	255	32.2	22	200	2	158	8	12.7
	400	89	255	42	26	200	7	158	8	17.4
	600	89	275	45.1	26	215.9	7	158	8	21.5
	900	89	290	51.5	32	235	7	158	8	27.7
	1,500	89	310	61	35	241.3	7	158	8	37
	2,500	89	355	83.2	42	273	7	158	8	65.7

Mb = effective diameter of diaphragm, x = number of drill holes

Further dimensions and higher nominal pressures on request

Ordering information

Diaphragm seal:

Diaphragm seal model / Process connection (standard, nominal width, nominal pressure, sealing face) / Materials (upper body, sealing face, diaphragm) / Flushing ring / Connection to the measuring instrument / Level of cleanliness of wetted parts / Design per NACE / Origin of wetted parts / Certificates

Diaphragm seal system:

Diaphragm seal model / Process connection (standard, nominal width, nominal pressure, sealing face) / Materials (upper body, sealing face, diaphragm) / Flushing ring / Pressure measuring instrument model (per data sheet) / Assembly (direct assembly, via cooling element or capillary) / min. and max. process temperature / min. and max. ambient temperature / vacuum service / System fill fluid / Certificates / Height difference / Level of cleanliness of wetted parts / Origin of wetted parts / Design per NACE / Diaphragm seal for mounting to zone 0 / Mounting bracket

© 2004 WIKA Alexander Wiegand SE & Co. KG, all rights reserved.
The specifications given in this document represent the state of engineering at the time of publishing.
We reserve the right to make modifications to the specifications and materials.

