

Solid Machined, to Weld-in or with Flange

Design per DIN 43 772 Form 4, 4F

Model TW55-6, TW55-7

WIKA Data Sheet TW 95.55

Applications

- Chemical industry, process technology, apparatus construction
- For high process loads

Special Features

- Design per DIN 43 772
- Thermowell Model TW55-6: Form 4 to weld-in
Model TW55-7: Form 4F with flange

Description

Thermowell material

Stainless steel 1.4571, 316/316L

Carbon steel 1.0460, 1.5415, 1.7335, 1.7380

Process connection

- Thermowell outer diameter (bar diameter)
Ø 18 mm, 24 mm, 26 mm, 32 mm ...
- Flanges to valid national or international standards like
EN 1092-1, DIN 2527, ASME

Instrument connection

M14 x 1.5, M18 x 1.5, G ½, G ¾ female

Bore size

Ø 3.5 mm, Ø 7 mm, Ø 9 mm, Ø 11 mm

Insertion length and total length

Version combinations see table on page 2

Maximum process pressure

Dependent upon pressure rating of flange

Weld-in thermowells see DIN 43 772



Fig. left: Thermowell to weld-in Model TW55-6

Fig. right: Thermowell with flange Model TW55-7

Options

- Other dimensions and materials
- Quality certificates
- Wake frequency calculations in accordance with ASME PTC 19.3 are recommended in critical applications. WIKA offer this as an engineering service.

Please find further information in our separate technical information sheet IN 00.15 "Strength calculation for thermowells"

- 1) Rating depends on the parameters below:
- Process medium
 - Process pressure and temperature
 - Flow rate
 - Design of thermowell (dimensions, material)

Dimensions in mm

3088944.02

Model TW55-7

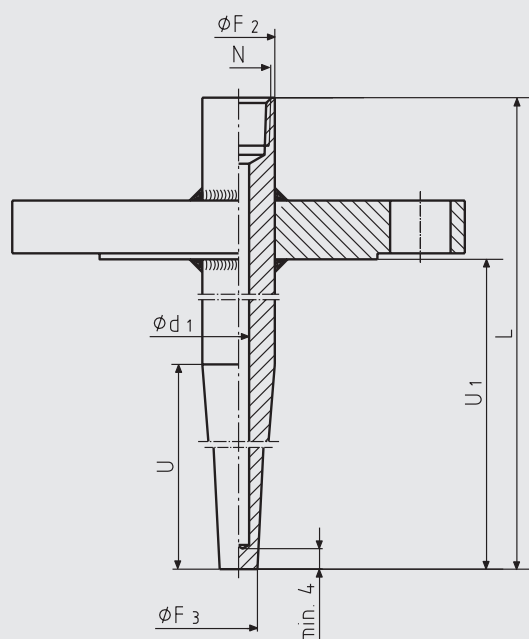

Model TW55-6

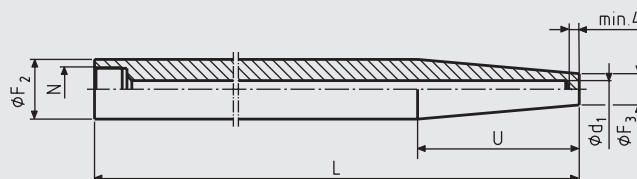

Legend:

- L Total length
- U_1 Insertion length
- U Length of tapered part
- N Instrument connection
- ϕd_1 Bore size
- ϕF_2 Thermowell outer diameter (bar diameter)
- ϕF_3 Thermowell tip diameter
- M Neck tube length

Model TW55-6 with neck tube

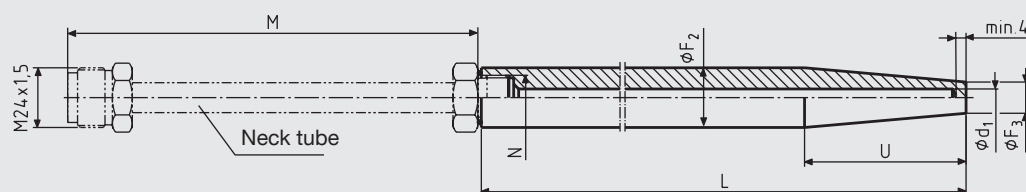

Standard lengths Model TW55-7

Dimensions in mm			Weight in kg	
L	U	U_1	DN 25, PN 40	DN 50, PN 40
200	65	130	1.9	3.8
260	125	190	2.1	4.0
410 ¹⁾	275	340	2.3	4.2

Standard lengths Model TW55-6

Dimensions in mm		Weight in kg
L	U	
110	65	0.240
110	73	0.230
140	65	0.340
170	133	0.340
200	65	0.540
200	125	0.450
260	125	0.650
410 ²⁾	275	0.920

Standard connection thread

Dimensions in mm					
N	ϕd_1	ϕF_2	ϕF_3	H_1	H_2
M14 x 1.5	3.5	18	9	16	13
M18 x 1.5	7	24	12.5	16	13
G 1/2	7	26	12.5	19	15
G 1/2	9	26	15	19	15
G 3/4	11	32	17	22	17

1) Not with bore size $\phi d_1 = 3.5$ mm

2) Standard neck length M = 165 mm

Suitable stem lengths (mechanical thermometers)

Design of connection	Stem length l_1	
	without neck tube	with neck tube
S / 4 / 5	$l_1 = L - 10 \text{ mm}$	-
2	$l_1 = L - 30 \text{ mm}$	-
3	-	$l_1 = L + M - 10 \text{ mm}^{2)}$

Suitable stem lengths (machine glass thermometers)

Design of connection	Stem length l_1	
	without neck tube	with neck tube
E	$l_1 = L - 10 \text{ mm}$	-
3	-	$l_1 = L + M - 10 \text{ mm}^{2)}$

2) Standard neck length M = 165 mm

Version combinations insertion length and total length in mm

Thermowell Model	Insertion length U_1	Length of tapered part U	Total length L
TW55-6 (Form 4 to weld-in)	-	65, 73, 125, 133, 275	110, 140, 170, 200, 260, 410
TW55-7 (Form 4F with flange)	130, 190, 340	65, 125, 275	200, 260, 410

Sealing surface roughness

Flange standard		AARH in μinch	Ra in μm	Rz in μm
ASME	Stock finish	125 - 250	3.2 - 6.3	-
B 16.5	Smooth finish	< 125	< 3.2	-
	RTJ	< 63	< 1.6	-
	Tongue / Groove	< 125	< 3.2	-
EN 1092	Form B1	-	3.2 - 12.5	12.5 - 50
	Form B2	-	0.8 - 3.2	3.2 - 12.5
DIN 2527	Form C	-	-	40 - 160
	Form E	-	-	< 16

Pressure-Temperature-Diagram 1)

Thermowell Model TW55 made of stainless steel 1.4571

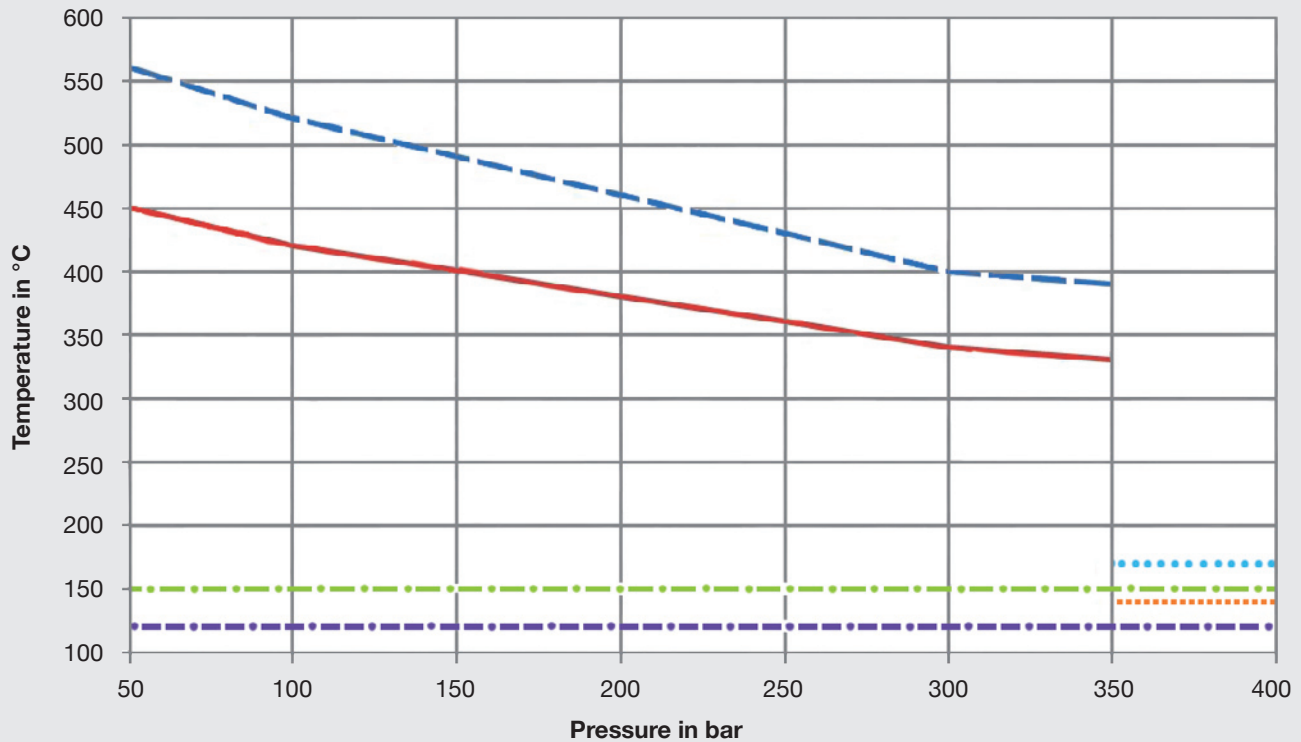

Legend:

- water 3 m/s U = 65 mm with ID Ø 3.5 mm
- water 3 m/s U = 125 mm with ID Ø 7 mm
- air 60 m/s U = 65 mm with ID Ø 3.5 mm
- air 60 m/s U = 125 mm with ID Ø 7 mm
- vapour 60 m/s U = 65 mm with ID Ø 3.5 mm
- vapour 60 m/s U = 125 mm with ID Ø 7 mm

- 1) Rating depends on the parameters below:
- Process medium
 - Process pressure and temperature
 - Flow rate
 - Design of thermowell (dimensions, material)

Modifications may take place and materials specified may be replaced by others without prior notice. Specifications and dimensions given in this leaflet represent the state of engineering at the time of printing.



WIKAI Alexander Wiegand SE & Co. KG
 Alexander-Wiegand-Straße 30
 63911 Klingenberg/Germany
 Tel. (+49) 9372/132-0
 Fax (+49) 9372/132-406
 E-mail info@wika.de
 www.wika.de